

> MONTAGEANLEITUNG  
 ASSEMBLY INSTRUCTIONS  
 NOTICE DE MONTAGE  
 ISTRUZIONI PER IL MONTAGGIO

**EINBAU / AUFBAUSCHALTER 230V/2,5A**  
**FITTED / MOUNTED SWITCH 230V/2,5A**

**CE** Konformitätskennzeichnung  
 EU conformity marking

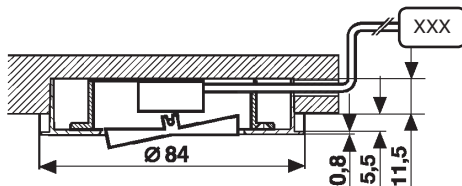
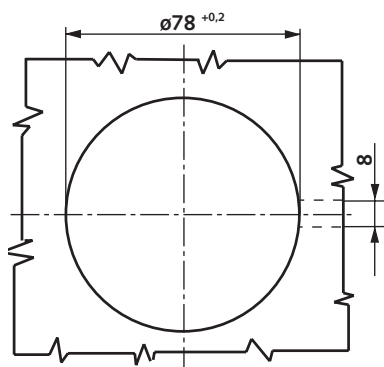
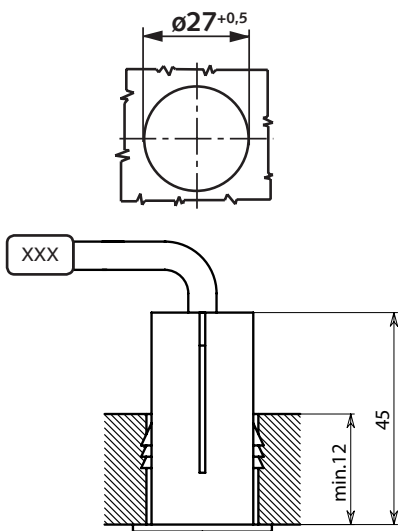
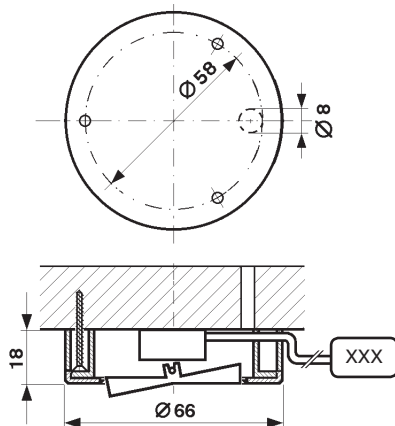
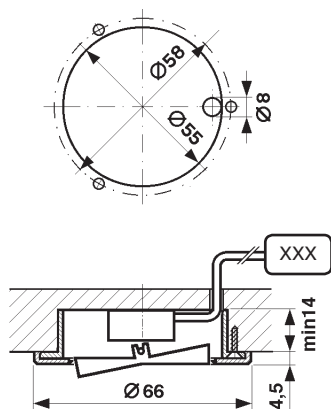

**XXX :**  
 diverse Anschlussmöglichkeiten  
 various Connector options

MA Art.-Nr. 540 098 39 06/10



ELEKTRA GMBH  
 Werkstraße 7  
 D-32130 Enger  
 Telefon 052 23/185-0  
 Fax 052 23/1 72 56